

IP65
WATERPROOF

DIRECT VIEW ELECTRONIC CRANE SCALES

- Dust/waterproof level: IP65
- LED display, remote control
- Low voltage indicator
- Unit: kg, lb
- Overload alarm
- Automatic power off
- Aluminum alloy die casting case with high strength
- 360° safe rotary hook and shackle

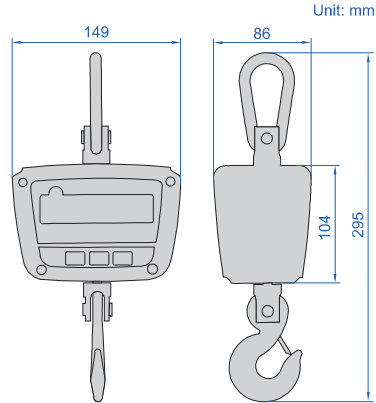

Remote controller
(included)



8201-150KG

SPECIFICATION

| Code | 8201-50KG | 8201-150KG | 8201-300KG |
|---------------------------|--|---------------|---------------|
| Maximum weighing | 50kg | 150kg | 300kg |
| Minimum weighing | 0.4kg | 1.0kg | 2.0kg |
| Resolution (d) | 0.02kg/0.01kg | 0.05kg/0.02kg | 0.10kg/0.05kg |
| Verification interval (e) | 0.02kg | 0.05kg | 0.10kg |
| Accuracy | ±0.02kg | ±0.05kg | ±0.10kg |
| Operating temperature | -10~40°C | | |
| Operating humidity | 30%~90% RH | | |
| Overload alarm | 100%F.S.+9e | | |
| Maximum safe load | 125%F.S. | | |
| Limited overload | 400%F.S. | | |
| Power supply | rechargeable battery 6V/3Ah (for 40 hours working) | | |
| Stable reading time | ≤8s | | |

STANDARD DELIVERY

| | |
|-------------------|------|
| Main unit | 1 pc |
| Remote controller | 1 pc |
| Battery charger | 1 pc |